

Flashpak Thermal Delivery System PTDS200

- Initial charge in 2.5 minutes or less.
- Recharges in 60 seconds (avg.)
- No-leak, solid-to-solid phase change material keeps pizzas hot for up to a 45 minute delivery.
- Light weight pellet and bag at 1.7kg.
- Extremely easy to implement with no pellet cord, no maintenance and no extra labour steps.
- Extremely easy to implement with no delivery bag cord, no maintenance, and no extra labor steps.
- Charger does not emit any heat on the locator surface.
- Charger performs self-diagnostic features and alerts user in the event of an error.
- User-friendly membrane panel and lighted displays are easy to understand and operate.
- Charger manufactured and designed to handle exposure to flour, dust, oil, grease and various other food substances found in food establishments.
- Charger unit manufactured and designed to operate on a standard countertop or "dropped-in" to a custom shelving unit.
- Charger operates on a single phase, 8A, 240V dedicated circuit.
- Three year limited warranty on the charger only.

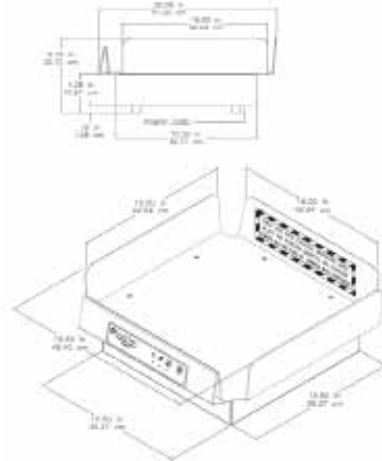

Model Number	PTDS200
Power requirements	240 V, 1 PH
Power consumption	1800 W
Voltage	240 V, 50/60Hz
Amperage	10 amps
Charger dimensions - Base (mm)	393 x 393 x 115H
Charger dimensions with bag locator (mm)	549 x 512x 217H